



INSTALLATION AND OPERATION MANUAL

SOFTWARE VERSION **13.x**
code **80343G** / Edition **19 - 11/07**

1 • INSTALLATION

• Dimensions and cut-out; panel mounting

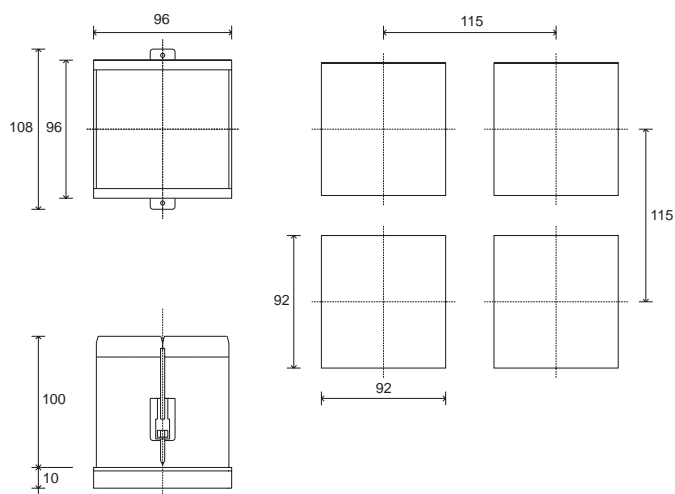
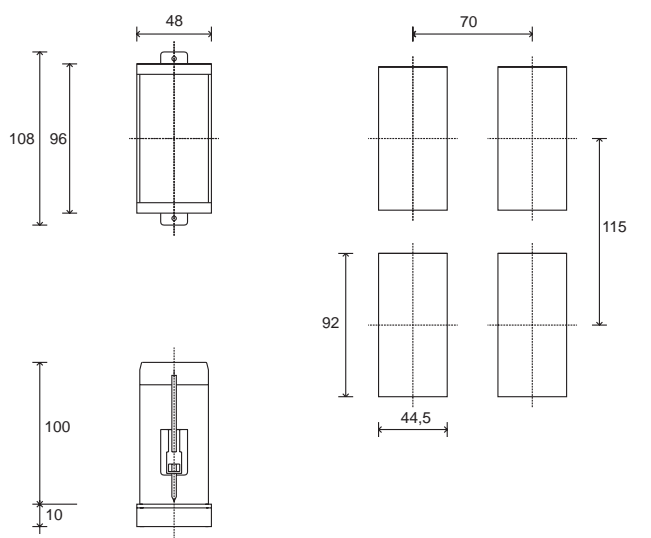

For correct and safe installation observe the warnings contained in this manual

Panel mounting:

To fasten the instruments insert the block into the seats on the sides of the box. To mount two or more instruments side by side respect the dimensions shown above.

2 • TECHNICAL SPECIFICATIONS

<i>Display</i>	2x3 digit green LEDs, digit height 14-10-20mm
<i>Keys</i>	3 mechanical keys (Raise, Lower, F)
<i>Accuracy</i>	0.5% f.s. ± 1 digit at 25° ambient temperature
<i>Main input (adjustable digital filter)</i>	TC, RTD, Sampling time 120 msec
<i>TC type(Thermocouples)</i>	for 1000 J (Fe-CuNi) 0...800°C / 32...999°F K (NiCr-Ni) 0...999°C / 32...999°F N (NiCr-Si-NiSi) 0...999°C / 32...999°F S (Pt10Rh-Pt) 0...999°C / 32...999°F R (Pt13Rh-Pt) 0...999°C / 32...999°F T (Cu-CuNi) -100...400°C / -148...752°F for 1001, 1101 J (Fe-CuNi) 0...800°C / 32...999°F K (NiCr-Ni) 0...1300°C / 32...1999°F N (NiCr-Si-NiSi) 0...1300°C / 32...1999°F S (Pt10Rh-Pt) 0...1600°C / 32...1999°F R (Pt13Rh-Pt) 0...1600°C / 32...1999°F T (Cu-CuNi) -100...400°C / -148...752°F Selection with faceplate keys.
<i>Cold junction error</i>	0.05°C for each 1°C of variation
<i>RTD type (scale configurable within indicated range, with or without decimal point)</i>	RTD 2/3 wires for 1000 Pt100 -19.9...99.9°C / -19.9...99.9°F Pt100 -199...400°C / -199...752°F RTD 2/3 wires for 1001, 1101 Pt100 -199.9...199.9°C / -199.9...199.9°F Pt100 -200...400°C / -328...752°F
<i>Max. RTD line resistanceRTD</i>	
<i>Safety</i>	detection of short circuit or opening of probes, LBA alarm, HB alarm
<i>°C / °F selection</i>	Faceplate configurable
<i>DC - Linears</i>	0...50mV, 10...50mV Input impedance > 1M Ω For signals 0...10V, 0...20mA, 4...20mA use only with dividers / shunt outside the instrument.
<i>Control actions</i>	Pid, Autotune, on-off
<i>pb - dt - it</i>	<ul style="list-style-type: none"> • Proportional band: 0.0...99.9% f.s. • Integral time: 0.0...99.9 min • Derivative time: 0.0...9.99 min (0.0...19.99 min) • Reset power (positioning of proportional band): 0...100%. • Hysteresis (only for On/Off control): -199...999 (-999...1999) digits.
Other specifications at page 16	

2 • TECHNICAL SPECIFICATIONS

<i>Action</i>	Main output (MAIN) with direct (heating), reverse (cooling) function.
<i>Control output</i>	On/Off, P, PD, PID control in heating and in cooling, with parameters settable with faceplate keys
<i>Cycle time</i>	-2...200 sec
<i>Main output time</i>	relay, logic, continuous (0...10V / 4...20mA)
<i>Softstart</i>	0.0 ... 99.9 min.
<i>Off function</i>	Software On/Off function to deactivate the instrument.
<i>Configurable alarms</i>	<ul style="list-style-type: none"> • 3 alarm limits settable to absolute, deviation, symmetrical deviation compared to setpoint, with reversible function (direct, reverse). • Setting of alarm point along entire selected scale. • Alarm (AL1) with PD output with settable parameters. <ul style="list-style-type: none"> - Proportional band set on hysteresis of AL1: -199...999 (-999...1999) digit. - Derivative time: 0,0...9,99 (0,0...19,99)min. - Cycle time: 1...200 sec (0 per allarme On/Off). • Alarm (AL3) can be used as load interrupt function (HB) linked to input from current transformer; configurable current scale. 0...99,9 (0...199,9) • Alarm selection with LBA output (open control loop). • Settable trip time and power supplied in LBA alarm state. • Alarm trip hysteresis (settable in range): -199...999 (-999...1999) digit.
<i>Other specifications</i>	<ul style="list-style-type: none"> • Manual reset (correction of control at full speed): -199...999 (-999...1999) digits. • Offset (setting of fixed difference between actual reading of input probe and value "read" by controller): -199...300 (-300...300) digits. - Automatic/Manual function with bumpless at switch to automatic.
<i>Type of relay contact</i>	With contacts 5A 250Vac at $\cos\phi = 1$; Spark suppression on NO contacts ;
<i>Logic output</i>	24Vdc $\pm 10\%$, Rout = 470 Ω (12V min. at 20mA). Protection on polarity reverse and short circuit..
<i>Continuous output</i>	0...20mA o 4...20mA on max resistance 500 Ω configurable to 0...10V with impedance of 500 Ω . Load resistance $\geq 47K\Omega$. (indicated in code with V and I)
<i>Serial interface</i>	Optically isolated, 4 wires. Passive Current Loop interface (1200 baud) or RS485 4 wires
<i>Baudrate</i>	1200 / 2400 / 4800 / 9600.
<i>Protocol</i>	Gefran CENCAL
<i>Current transformer input options</i>	T.A. 5Aac, 50/60Hz, Ri = 16m Ω
<i>Power supply (switching)</i>	Standard: 100...240Vac/dc $\pm 10\%$ on request: 11...27Vac/dc $\pm 10\%$ 50/60Hz; 9VA max. Protected by internal fuse not serviceable by user.
<i>Faceplate protection</i>	IP 54
<i>Working / Storage temperatures</i>	0...50°C -20...70°C
<i>Relative humidity</i>	20...85% Ur non-condensing
<i>Environmental conditions of use</i>	for internal use only, altitude up to 2000m
<i>Installation</i>	Panel mounting, extractable from front
<i>Weight</i>	320g (1000) 400g (1001, 1101)

EMC conformity has been tested with the following connections

FUNCTION	CABLE	LENGTH USED
Power supply cable	1 mm ²	1 m
Relay output cables	1 mm ²	3,5 m
Serial connection cable	0,35 mm ²	3,5 m
CT connection wires	1,5 mm ²	3,5 m
Tc input probe	0,8 mm ² compensated	5 m
"PT100" input probe	1 mm ²	3 m

CE MARKING: EMC (electromagnetic compatibility) conformity to EEC Directive 89/336/EEC with reference to the generic Standard CEI-EN61000-6-2 (immunity in industrial environments) and EN50081-1 (emission in residential environments). BT (low voltage) conformity to Directive 73/23/EEC as modified by Directive 93/68.

MAINTENANCE: Repairs must be done out only by trained and specialized personnel. Cut power to the device before accessing internal parts. Do not clean the case with hydrocarbon-based solvents (Petrol, Trichlorethylene, etc.). Use of these solvents can reduce the mechanical reliability of the device. Use a cloth dampened in ethyl alcohol or water to clean the external plastic parts.

SERVICE: In GEFran è disponibile un reparto di assistenza tecnica. The warranty excludes defects caused by any use not conforming to these instructions.

3 • DESCRIPTION OF FACEPLATE

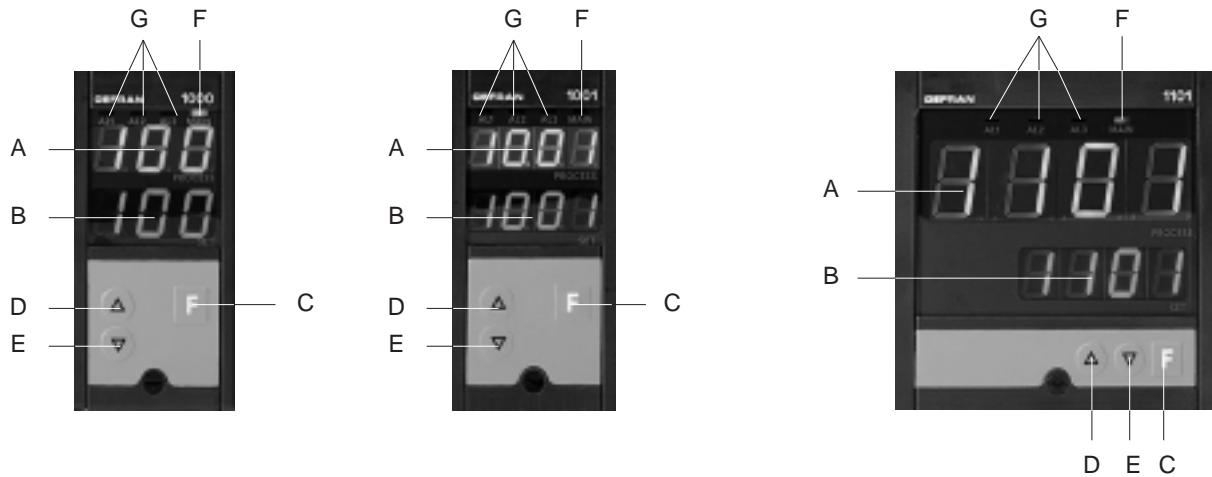

A - Digit height 14mm (1000), 10mm (1001), 20mm (1101) green

Value of variable controlled to 3 digits (1000) 3^{1/2} digits (1001 -1101)

Indication - 199...+999 (1000) indication -999...+1999 (1001-1101) with decimal point on appropriate scales.

Positive (HI) or negative (LO) off-scale message Message for broken/incorrect connection of probe; (SBR: open circuit / ERR: probe reversed) and display of configuration and calibration messages.

B - Digit height 14mm (1000), 10mm (1001), 14mm (1101) green. Setpoint value.

Alarm limit range -199...+999 (1000) -999...+1999 (1001-1101).

Alarm limits are accompanied by flashing of AL 1 AL2 AL3/HB LEDs.

Main output value in percentage(0...99%) followed by letter P. Parameter values and configuration data.

C - Function key

Accesses setpoint and alarm functions (each function is specified by flashing of LED for reading and/or changing of values. If the F key is not pressed to confirm a change, saving is done automatically after 10 sec. and the display returns to setpoint value.

The F key accesses the various configuration and saving procedures for changed settings.

D - Raise Key / **E** - Lower Key

These keys raise or lower the value of the displayed function.

The raising (lowering) speed is proportional to the time the key is pushed.

The procedure is not cyclical. When the maximum (minimum) of the setting range is reached with the key pushed, the raise (lower) function stops.

F - Main output on. Green LED

G - Alarm signal. Red LED

Faceplate protection IP54 (IP65 available)

4 • CONNECTIONS

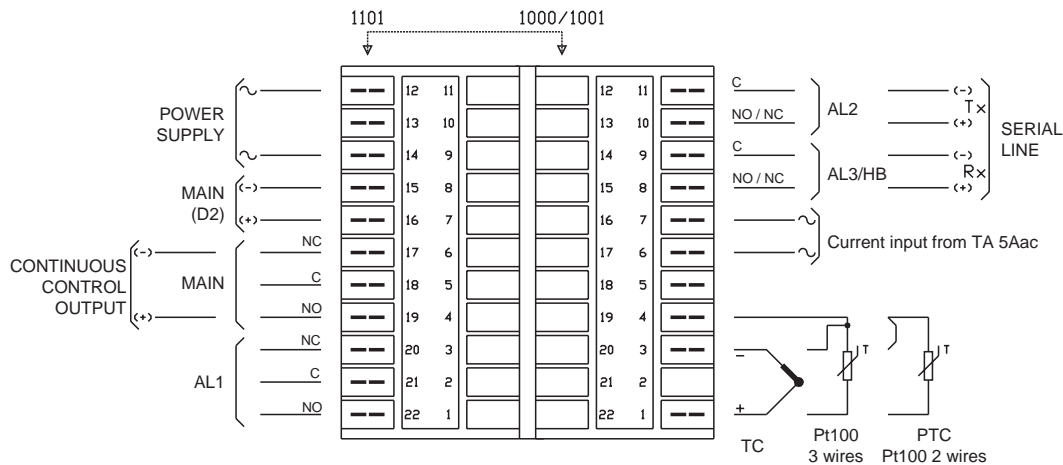

21 connections are available for 6.35 mm faston terminals.

Signal inputs

Inputs from TC or RTD (2 wires) are attached to faston 1 (positive) and 3 (negative). (Short circuit 3 and 4 for RTD with 2 wires).

For RTD with 3 wires, the single wire is attached to faston 1; for the remaining wires, one goes to faston 3 and the other to 4.

Input from current transformer (HB function)

If the instrument accepts this input, the signal must be attached to faston 6 and 7; Secondary current input for CT, impedance 20mΩ, 5A, 50/60Hz.

Power supply

Voltage (100...240Vac) is attached to fastons or terminals 12 and 14. A version with 11...27Vac/dc voltages is available.

Fuse

Inside instrument, not replaceable by user.

Power supply	Type	Current	Voltage
100...240Vac	T	0.5A	250V
11...27V	T	1.25A	250V

Main output

Relay output to terminals or fastons 19 (N.O.) 18 (C) and 17

(N.C.); contact capacity 5A at $\cos\phi = 1$

Logic output type D2 24V is available to fastons 16 (positive) and 15 (negative). Continuous output to terminals or fastons 19 (+) and 17 (-) as alternate to relay output.

Alarm outputs

For alarm relays: terminals or fastons 20 (N.C.) 21 (C) and 22 (N.O) for alarm 1; terminal faston 11 and 10 (N.C. o N.O.) for alarm 2; terminals 9 and 8 (N.C. o N.O.) for alarm 3/HB.

NC contacts are available for alarms 2 and 3 by changing the jumpers. Contact capacity is 5A for alarms 1, 2 and 3.

Digital communication (Current loop / 485)

If the instrument accepts a 1200 baud Passive Current Loop interface, the reception diode is available at fastons 8 (Rx+) and 9 (rx-); transmission transistor to fastons 10 (Tx+) and 11 (tx-). In standard configuration for parallel connection on the serial line, the resistance in series to the diode is 1K Ohm; 100 Ohm to the transistor collector.

For the series connection, the resistance in series to the diode is 100 Ohm. If the instrument accepts 1200...9600 baud 4-wire RS485 interface, reception is available to fastons 8 (Rx+) and 9 (Rx-); transmission to fastons 10 (Tx+) and 11 (Tx-). (See hardware configuration in Appendix).

5 • HARDWARE CONFIGURATION

Data and figures are given in the Appendix

Hardware protection

To remove the electronic part of the case, loosen the front screw until release, then remove by hand. Configuration is performed on the input board, the output/power board, and on the optional board.

6 • WORK MODE

Display of process variable, load current, output power.

Setting setpoint and alarms

AUTO/MAN function

Software On/Off function

Introduction

Work mode lets you monitor the main process quantities: process variable, load current, control output power, while output state (MAIN and alarms) is signaled by their LEDs. It also lets you display and set the setpoints and alarms.

You can scroll the seven work processes (see table below) by means of the F key.

Use the Raise and Lower keys to set the setpoints and alarms. .

Confirm the set value by pressing the F key, if the key is not pressed, the value will be confirmed automatically 10 seconds after the last change.

Enabling the various phases depends on the hardware and software configuration and on the software protection level that is set (Pro code in CFG.2 procedure). In minimum configuration, only

Start/Stop selftuning

Versione software

Messaggi di errore e segnalazioni

Power on

phases 0 and 1 are available.

At power-on, after the display has finished flashing, the instrument goes to work mode phase 0 (automatic start), or to phase 6 (manual start).

Specific combinations of keys let you switch between automatic and manual, turn the software off and on, start or interrupt self-tuning.

Work mode is the starting point for access to Programming, Configuration and Calibration phases.

6 • WORK MODE

Sequence of phases in work mode

Work phase	Upper display	Lower display	Phase indication	Notes
0	Process variable	Control setpoint*		Note 1
1	Process variable	Alarm limit 1 *	Led AL1 flashing	Note 2
2	Process variable	Alarm limit 2 *	Led AL2 flashing	Note 2
3	Process variable	Alarm limit 3 *	Led AL3 flashing	Note 2
4	CT input value	Alarm limit HB *	Letter A flashing	Note 3
5	Process variable	CT input value	Letter A steady	Note 4
6	Process variable	Auto/Man power outputn	Letter P steady/flashing	Note 5

* *settable value, return to work phase 0 after 10 seconds.*

Notes:

1. Work phase 0 (SP)

In normal operation, the upper display shows the process variable (PV) (measured at input), while the lower display shows the control setpoint. A change in setpoint takes effect immediately.

2. Work phase 1,2,3 (alarms)

Alarm 1 is always enabled. Alarms 2 and 3 depend on the value of the brd code (in CFG2), which reflects the hardware configuration. If one of the three alarms is configured as HB (see code **A.r.F.** in CFG2) phase 4 will appear instead of phases 1,2 or 3, with the respective LED flashing. If it is configured as LBA, the respective phase will not appear. See Functional Notes/Alarms.

3. Work phase 4 (HB alarm)

Enabled only if the instrument has the CT input (see brd code) and if the HB alarm is enabled (see **Out** code in CFG2). Signaled by flashing of letter "A" on least significant digit of lower display. The most significant digits display the whole value of the HB limit, while the upper display shows the value of current in the load read by the CT input in Ampere (resolution 0.1 Ampere). Press the Raise or Lower key instead of letter A to see the decimal figure of the limit that persists during the change. When the key is released, "A" reappears after 1 second. Press F to confirm the set value and go to the next phase. See Functional Notes/Alarms/HB Alarm.

4. Work phase 5 (CT input)

Enabled only if the instrument has the CT input (see code **brd**), and is independent of the HB alarm. The lower display shows the whole value of the load current, followed by letter "A" (steady). It remains on the display without time limit. See Functional Notes/CT input function.

5. Work phase 6 (POWER)

Accessible only with the AUTO/MAN function engaged (see brd code in phase CFG.2). A detailed description of the AUTO/MAN function may be found in Functional Notes / AUTO/MAN function.

AUTO/MAN and MAN/AUTO switching

In work phase 6, press the Raise and Lower keys simultaneously to switch from automatic to manual. Press F to switch from manual to automatic. ("P" steady in automatic, flashing in manual). In manual, you can vary output power directly with the Raise and Lower keys. See Functional Notes

Self-tuning Start/stop

Press the F and Raise keys simultaneously for 3 seconds to activate the self-tuning procedure. The same command interrupts the procedure. See Functional Notes / SELF-TUNING.

Software On/Off

Press the F and Lower keys simultaneously for 5 seconds to put the instrument in OFF status (display off, outputs deactivated). Press F for 5 seconds to activate the instrument. See the specific section in Functional Notes.

Display of software release number

Keep the "F" key pressed for 3 seconds: the upper display will show the message Upd and the lower display the software release number (ex. Upd/11.0). When the key is released, the display returns to work mode, phase 0.

Error messages and signals

Message **Sbr** on upper display: probe input interrupted (TC-RTD) .

Message **Err** on upper display: incorrect connection; probe reversed (TC); probe in short circuit (RTD).

Message **Lo** on upper display: off scale low.

Message **Hi** on upper display: off scale high.

Upper display flashing: self-tuning or soft-start in progress. Upper and lower display flashing: LBA alarm on. Two decimal points (one only for scales with decimal point) flashing on upper display: auto-tuning on. Decimal point flashing with display off: instrument in software off (OFF) status.

P flashing on lower display: work phase 6 MAN mode (power settable from faceplate keys).

P steady on lower display: work phase 6 AUTO mode (power display in automatic).

A flashing on lower display: work phase 4 (HB alarm limit setting

A steady on lower display: work phase 5 (ammeter input display).

Led AL1, AL2, AL3 flashing: alarm limit setting phase..

Led AL1, AL2, AL3 on: alarm relay energized.

Led AL1, AL2, AL3 off: alarm relay de-energized or alarm not enabled.

MAIN LED on: MAIN output on (MAIN relay energized, output D2 logic level 1)

MAIN LED off: MAIN output off (MAIN relay de-energized, output D2 logic level 0)

MAIN LED flashing rapidly: continuous output (LA) on.

Power on

At power-on, the instrument runs a 5-second initialization cycle during which the outputs are disengaged (relays de-energized, D2 and continuous outputs OFF) and all segments and LEDs on the display flash. The instrument then goes to work phase 0 (automatic start) or 6 (manual start). For the duration of the first cycle time, the software filter on the signal input is disengaged.

7 • PROGRAMMING

Introduction to setting and configuration procedures

Programming is performed in 3 phases:

0) Setting **1/2) Configuration**

These phases are accessed with the **F** key.

Phase 0 / Setting

In normal operation, press key F for 5 sec. to set the following parameters:

Pb / Proportional band in range 0.0...99.9% F S.

If the control is ON/OFF (integral, derivative, and cycle time null), the set value defines hysteresis -199...+999 (1000) -19.9...+99.9 (1000 scale with decimal point) -999...+1999 (1001-1101) -99.9...+199.9 (1001-1101 scale with decimal point).

rSt / Manual reset in range -199...+999 (1000) -19.9...+99.9 (1000 scale with decimal point) -999...+1999 (1001-1101) -99.9...+199.9 (1001-1101 scale with decimal point).

When the control has settled, bring the value of the controlled quantity exactly to the setpoint (at times this is necessary in PD control).

_Ct: Cycle time in range -2...200. By setting Ct=0, the cycle time is excluded and the control becomes ON/OFF (in this case, Pb becomes hysteresis in scale points). By setting Ct = -1, you get fast PWM output with cycle time (duty cycle) fixed at 100 milliseconds, usable only with output D2 or with continuous output 0...10V or 0...20mA. Set Ct = -2 for continuous output 2...10V or 4...20mA. Values Ct = 1 a 200 are considered as cycle time in seconds.

P.St: Reset power in range 0 -100%. Reset action equals free positioning of the Proportional band. By setting 0 the P B. is below the setpoint; by setting 100 the P.B. is completely above the setpoint (with main output in direct function). In case of ON/OFF control, the reset power set has no effect.

S.tu: Insertion of Self and Auto-tuning function (see table).

S.tu	SELF	AUTO	SOFT-START
0	NO	NO	NO
1	NO	YES	NO
2	YES	NO	NO
3	YES	YES	NO
4	NO	NO	YES
5	NO	YES	YES

+8 o disable the software filter on the controlled variable (recommended for linear scales)

Automatic turn-off of self-tuning at end of calculation

_Lb.t/ Wait time for tripping of LBA alarm (1 ...240 min); by setting 0, the LBA function is deactivated.

_Lb.P/ Power supplied when LBA alarm is active, settable in range 0...100%. When setting is complete, press the F key to return to normal operation.

Configuration Phase 1 (CFG1)

To access phase 1, press the F key until the message CFG1 appears on the display.

_It: Integral time in range 0.0...99.9 min (by setting 0.0, the integral action is excluded). A high integral time generates a weak integral action, while a short integral time generates a strong integral action

_dt/ Derivative time in range 0.00...9.99 min (1000) 0.00...19.99 min (1001-1101) (by setting 0.00 the derivative action is excluded).

The effectiveness of the derivative action increases proportionately with the derivative time.

SOFT: Soft-start time in range 0.0...99.9 min (by setting 0.0 the

the Soft-start action is excluded).

The Soft-start action concludes at the set time or with the controlled variable in Proportional band.

Hy1: Hysteresis or Proportional band (PD) for AL1 in range -199 +999 digit (1000) -19.9...+99.9 (1000 scale with decimal point) -999...+1999 (1001-1101) -99.9...+199.9 (1001-1101 scale with decimal point). A negative (or positive) number indicates a hysteresis band positioned below (or above) the alarm limit, and is characteristic of a direct (or reverse) alarm.

Hy2: Hysteresis for AL2 in range -199.. +999 digit (1000) -19.9.. +99.9 (1000 scale with decimal point) -999...+1999 (1001 1101) -99.9...+199.9 (1001-1101 scale with decimal point).

Hy3/ Hysteresis for AL3 in range -199...+999 digit (1000) -19.9...+99.9 (1000 scale with decimal point) -999...+1999 (1001-1101) -99.9...+199.9 (1001-1101 scale with decimal point).

Hb.s is selectable only on instruments equipped with input from current transformer (CT). Full scale current setting from 0...199.9 (99.9).

no /Instrument code connection in serial line in range 0...999; appears only for instruments equipped with serial communication (version 1 H), with specific setting of "brd" code (see CFG2).

baU/ Baud rate for serial communication as per the table:

0	1200 baud	CL, 485
1	2400 baud	CL, 485
2	4800 baud	485
3	9600 baud	485

Available only for instruments fit with a serial card, with specific setting of "brd" code (see CFG.2).

N.B.: for information on the serial protocol, see the manual entitled "Introduction to serial communication".

FA.P/ "Fault action" power in range 0-100%. Supplied to main output in case of broken input probe (Sbr or Err signal on display)

Configuration Phase 2 (CFG2)

Access to phase CFG2 is conditioned by the closing of jumper S9 on the CPU board on components side (see Hardware Configuration).

Pro: Software protection level in range 0-31 as per the table.

Pro	Setpoint	Alarms	Phase 0	It, dt	CFG1
0	DISPLAY <>	DISPLAY <>	DISPLAY <>	DISPLAY <>	DISPLAY <>
1	DISPLAY <>	DISPLAY <>	DISPLAY <>	DISPLAY <>	
2	DISPLAY <>	DISPLAY <>	DISPLAY <>	DISPLAY	
3	DISPLAY <>	DISPLAY <>	DISPLAY <>		
4	DISPLAY <>	DISPLAY <>	DISPLAY		
5	DISPLAY <>	DISPLAY <>			
6	DISPLAY <>	DISPLAY			
7	DISPLAY	DISPLAY			
DISPLAY = DISPLAY			<> = SETTING		

+8 to disable the ON-OFF function from the panel keys

+16 to inhibit the AUTO/MAN function (only for instruments with AUTO/MAN function): only power display in **Automatic** remains displayed.

7 • PROGRAMMING

Standard protection level 19. Phase CFG2 parameters are not subject to software protection (access to phase CFG2 depends only on state of jumper S9 (HW config.).

AI: Alarm output function.

Configuration of symmetrical deviation alarms requires setting of positive setpoints only. For correct function, negative values are not allowed (even if settable).

0 = Alarms 1 and 2 direct absolute (relay energized when alarm limit is exceeded).

1 = Alarm 1 deviation, Alarm 2 absolute, both direct.

2 = Alarm 1 absolute, Alarm 2 deviation, both direct.

3 = Alarm 1, Alarm 2 direct deviation.

4 = Alarm 1 reverse absolute

(relay energized below alarm limit),

Alarm 2 direct absolute.

5 = Alarm 1 reverse deviation, Alarm 2 direct absolute.

6 = Alarm 1 reverse absolute, Alarm 2 direct deviation.

7 = Alarm 1 reverse deviation, Alarm 2 direct deviation.

8 = Alarm 1 direct absolute, Alarm 2 reverse absolute.

9 = Alarm 1 direct deviation, Alarm 2 reverse absolute

10 = Alarm 1 direct absolute, Alarm 2 reverse deviation.

11 = Alarm 1 direct deviation, Alarm 2 reverse deviation.

12 = Alarm 1, Alarm 2 reverse absolute.

13 = Alarm 1 reverse deviation, Alarm 2 reverse absolute.

14 = Alarm 1 reverse absolute, Alarm 2 reverse deviation.

15 = Alarm 1, Alarm 2 reverse deviation.

By adding **16** to the selected function code (ex. 9+16 setting 25), AL1 becomes symmetrical deviation: in this case, a direct alarm corresponds to an alarm with relay energized outside the "window", while a reverse alarm corresponds to an alarm with relay energized inside.

By adding **32**, AL2 becomes symmetrical deviation.

By adding **48**, both alarms become symmetrical deviation.

Out: Main output function (Heat/Cool) and AL1 (PD) enable HB alarm and selection of temperature scale (°C or °F)

Set code for selected combination of functions as per the table.

Nr.	AI.HB	AL1	OUT	Scale
0	Disabled	NO PD	HEAT	°C
1	Enabled	NO PD	HEAT	°C
2	Disabled	PD	HEAT	°C
3	Enabled	PD	HEAT	°C
4	Disabled	NO PD	COOL	°C
5	Enabled	NO PD	COOL	°C
6	Disabled	PD	COOL	°C
7	Enabled	PD	COOL	°C
8	Disabled	NO PD	HEAT	°F
9	Enabled	NO PD	HEAT	°F
10	Disabled	PD	HEAT	°F
11	Enabled	PD	HEAT	°F
12	Disabled	NO PD	COOL	°F
13	Enabled	NO PD	COOL	°F
14	Disabled	PD	COOL	°F
15	Enabled	PD	COOL	°F

By adding the following 6 STEPS to the 16 combinations, you can get various combinations for AL3.

+0 AL3 NORMAL DIRECT ABSOLUTE

+16 AL3 DEVIATION DIRECT NORMAL

+32 AL3 ABSOLUTE REVERSE NORMAL

+48 AL3 DEVIATION REVERSE NORMAL

+80 AL3 DEVIATION DIRECT WINDOW

+112 AL3 DEVIATION REVERSE WINDOW*

When limit AL3 = 0 or is negative, AL3 remains energized or de-energized at all times.

Note: The PD alarm cannot be symmetrical.

TyP/ Type of input probe or linear scale.

Code	1000	1001/1101
0	J 0...800°C/32...999°F	J 0...800°C/32...1472°F
1	K 0...999°C/32...999°F	K 0...1300°C/32...1999°F
2	N 0...999°C/32...999°F	N 0...1300°C/32...1999°F
3	S 0...999°C/32...999°F	S 0...1600°C/32...1999°F
4	R 0...999°C/32...999°F	R 0...1600°C/32...1999°F
5	T -100...400°C -148...752°F	T -100...400°C -148...752°F
6	PT100 -199...400°C -199...752°F	PT100 -200...400°C -328...752°F
7	PT100 -19,9...99,9°C -19,9...99,9°F	PT100 -199,9...199,9°C -199,9...199,9°F
8	0-50mV no decimals (xxx)	0-50mV no decimals (xxxx) -999...1999
9	0-50mV 1 decimals (xx.x)	0-50mV 1 decimals (xxx.x)
10	0-50mV 2 decimals (x.xx)	0-50mV 2 decimals (xx.xx)
12	10-50mV no decimals (xxx)	10-50mV no decimals (xxxx)
13	10-50mV 1 decimals (xx.x)	10-50mV 1 decimals (xxx.x)
14	10-50mV 2 decimals (x.xx)	10-50mV 2 decimals (xx.xx)

For TC probes type S and R, precision is in the instrument class (0.5%) for temperatures > 200°C

Ct.A / AL1 Cycle time in range 0...200 sec.

dt.A / AL1 Derivative time in range 0.00...9.99 min. (1000)
0.00...19.99 min (1001-1101).

oFt / Input offset adjustment

for 1001/1101:

-300/300 for type 0,1,2,3,4,5,6,8

-30.0/30.0 for type 7,9

-3.00/3.00 for type 10

for 1000:

-199/300 for type 0,1,2,3,4,5,6,8

-19.9/30.0 for type 7,9,

-1.99/3.00 for type 10

LO.S / Minimum value of setpoint and absolute alarms in scale range of selected probe. Start of linear scale for probe type 8, 9, 10, 12, 13, 14

HI.S / Maximum value of setpoint and absolute alarms in scale range of selected probe. End of linear scale for probe type 8,9,10, 12, 13, 14.

rEL/ Setting of alarm output state in case of broken probe (message Sbr/Err on display), according to table:

rEL	Output AL1	Output AL2	Output AL3
0	ON	ON	ON
1	ON	ON	OFF
2	OFF	ON	ON
3	OFF	ON	OFF
4	ON	OFF	ON
5	ON	OFF	OFF
6	OFF	OFF	ON
7	OFF	OFF	OFF

Note: In case of broken probe, each relay assumes the set state (ON = energized, OFF = de-energized), which does not depend on the type of alarm (direct or reverse).

7 • PROGRAMMING

Ar.F/ Selection of alarm output function.

Let you assign one of the following functions to each alarm output: Normal Alarm, HB Alarm, LBA Alarm, Alarm disabled (OFF logic state). Choose one of the 63 combinations according to the table:

Ar.F	Output AL1	Output AL2
0	AL1	AL2
1	HB	AL2
2	LBA	AL2
3	OFF	AL2
4	AL1	HB
5	HB	HB
6	LBA	HB
7	OFF	HB
8	AL1	LBA
9	HB	LBA
10	LBA	LBA
11	OFF	LBA
12	AL1	OFF
13	HB	OFF
14	LBA	OFF
15	OFF	OFF

By setting +0 output AL3 has function AL3
 By setting +16 output AL3 has function HB
 By setting +32 output AL3 has function LBA
 By setting +48 output AL3 is always OFF

Notes:

- The output state can be reversed by setting its alarm to reverse (code AL for outputs AL1 and AL2 and code Out for output AL3, in CFG.2 phase)
- The selection for outputs AL2 and AL3 is inoperative in case of configuration type "relay not present" (see brd code)
- Function "ArF" has priority over function "Out".

Ctr/ Selection of type of PID control and means of switching from automatic to manual according to table:

Ctr	PID control for:	Switching from Auto/Manual
0	Slow process (ts=8sec)	with power man. saved
1	Fast process (ts=1sec)	with power man. saved
2	Slow process (ts=8sec)	with power autom. current
3	Fast process (ts=1sec)	with power autom. current

Notes: sample time for actions I and D

A fast process is defined as one with main time constant less than 60 seconds. It is advisable to disable the digital filter on the input in case of PID for fast processes (see S.tu code in phase 0).

Hb.F/ Selection of type of HB alarm from 4 different choices:

- 0 - alarm trips when load current (CT input) drops below limit set for ON time of MAIN output
- 1 - alarm trips when ammeter full scale (Hb.S) in main output

OFF time is exceeded by 12%.

2 - alarm trips if one of functions 0 and 1 (described above) is active. (OR logic between functions 0 and 1)

3 - HB alarm for continuous output (PWM, setting _Ct = -1 or -2); does not take account of ON/OFF times and presupposes a special ammeter card with hw integration of load current.

NOTES: disabled if the output power is < 3%

Notes:

- code Hb.F is accessible only with ammeter input card installed (see brd code) and HB alarm enabled (code Out in CFG.2)
- see also ALARM FUNCTIONS / HB ALARM

brd/ Hardware model code and enabling of automatic / manual (A/M) function

brd	Display	A/M	Relé AL2	Relé AL3
0	3 digit	disabled	not installed	not installed
2	4 digit	disabled	not installed	not installed
4	3 digit	enabled	not installed	not installed
6	4 digit	enabled	not installed	not installed
8	3 digit	disabled	installed	not installed
10	4 digit	disabled	installed	not installed
12	3 digit	enabled	installed	not installed
14	4 digit	enabled	installed	not installed
16	3 digit	disabled	not installed	installed
18	4 digit	disabled	not installed	installed
20	3 digit	enabled	not installed	installed
22	4 digit	enabled	not installed	installed
24	3 digit	disabled	installed	installed
26	4 digit	disabled	installed	installed
28	3 digit	enabled	installed	installed
30	4 digit	enabled	installed	installed

Add 64 to code to configure the model with input from current transformer.

Add 128 to code to configure the model with serial communication CL or 485.

Notes:

- The selected configurations must conform to the instrument's hardware model. An incorrect selection may cause functioning not conforming to specifications.
- The brd code can be changed only with jumper S8 closed (Hardware Configuration / CPU Input Card).
- The brd code is also available in calibration phase.

Notes: The configuration model with serial communication CL or RS485 in alternative to relé AL2 and AL3 outputs.

8 • CALIBRATION

Enable configuration and calibration as described in the manual in the Hardware Configuration section (jumpers "S9" and "S8" closed).

In phase **CFG/2** (Configuration 2) set the type of input probe: parameter **tyP**:

tyP = 0,1,2,3,4,5 for thermocouples J,K,N,S,R,T

tyP = 6,7 for resistance thermometers Pt100

tyP = 8,9,10 for linear input 0 ..50mV

tyP = 12,13,14 for linear input 10 ..50mV

tyP = 11 for resistance thermometers Pt100 special case -19.9 ..99.9 (199.9)°C with hardware modification.

Quit phase CFG/2; the instrument returns to normal operation. Proceed to calibration with the instrument ON for at least 5-10 minutes. Calibrate as follows:

A) Calibration of thermocouples J,K,N,S,R,T and linear input 0-50mV/10-50mV.

A.1) Keep the F key pressed until **CAL** appears on the display; release F

A.2) Connect a 50.00mV signal from a calibrator between terminals 1 (+) and 3 (-).

A.3) Press F: the display shows message **CAL/50**; wait about 6 seconds.

A.4) Press F: the display shows message **t.A/25.0**; with the raise and lower keys, set the real value of the room temperature in which you are performing the calibration procedure (example: t.A = 23.7°C). You do not have to set the room temperature for linear inputs

A.5) Press F: the display shows **brd/valore**; set the hardware model code (see brd table in CFG.2 phase).

A.6) Press F to end the calibration procedure; the instrument will return to normal operation.

If the 50mV signal remains in input, the display shows message **_Hi** for tyP = 0,1,2,3,4,5 (thermocouples) or maximum scale for tyP = 8,9,10,12,13,14 (linear scale).

The thermocouple and linear input is now calibrated.

B) Calibration of Pt100 2/3 wires resistance thermometer input (tyP =6 or 7).

B.1) Keep the F key pressed until **CAL** appears on the display; release F

B.2) Press F; the display shows message **CAL/18**; between terminals 1 and 3, connect a resistance of 18.49 Ohms or a calibrator signal of -200.0°C; short circuit terminals 3 and 4; wait about 10 seconds

B.3) Press F: the display shows message **CAL/250**; between terminals 1 and 3, connect a resistance of 250.00 Ohms or a calibrator signal of +408.6°C; keep the short between terminals 3 and 4; wait about 10 seconds.

B.4) Press F: the display shows **brd/value**; set the hardware model code (see brd table in CFG.2 phase).

B.5) Press F to end the calibration procedure; the instrument will return to normal operation. If the 250 Ohm resistance remains in input, the display shows message **_Hi**. The Pt100 input is now calibrated.

D) Calibration of CT (ammeter) input for HB alarm.

The procedure is enabled only if the hardware accepts this type of input (see brd code in CFG.2).

D.1) Keep the F key pressed until **Hb.C** appears on the upper display. Between fastons 6 and 7, connect a 5A AC signal.

D.2) Press the F key: the display shows message **Hb.C/5**; wait about 6 seconds.

D.3) Press the F key to end the CT input calibration procedure; the instrument will return to normal operation. If the 5A current remains in the CT input, the current value (accessible with key F) will show the set full scale (parameter Hb.S in phase CFG/1). The CT input is now calibrated.

9 • CONTROL ACTIONS

Proportional Action: action in which the contribution on the output is proportional to the deviation in input (deviation is the difference between the controlled variable and the value you want).

Derivative Action: action in which the contribution on the output is proportional to the speed of variation of the deviation in input.

Integral Action: action in which the contribution on the output is proportional to the integral in time of the deviation in input.

Influence of Proportional, Derivative and Integral actions on response of process under control.

- Increasing the proportional band reduces oscillations but increases deviation.
- Reducing the proportional band reduces deviation but causes oscillations of the controlled variable (excessively low proportional band values make the system unstable)

- Increasing derivative action corresponds to an increase of derivative time, reduces deviation and avoids oscillations up to a critical value of derivative time, beyond which deviation increases and extended oscillations occur.

- Increasing integral action corresponds to a reduction of integral time, tending to cancel deviation under normal working conditions between the controlled variable and the value you want (setpoint).

If the integral time value is too long (weak Integral Action), there may be persistence of the deviation between the controlled variable and the value you want.

In this case, you should reduce the proportional band and increase the Derivative and Integral Actions until you get the result you want.

10 • FUNCTIONAL NOTES

• SOFTWARE ON/OFF FUNCTION

Turning off. you can deactivate the instrument by simultaneously pressing the F and Lower keys for 5 seconds. The instrument goes into "OFF" status, similar to shutdown status except that power is not turned off. During this "OFF" status, the display is off, with the decimal point flashing on the second digit of the lower display to indicate the presence of line voltage; all outputs (control and alarms) are in OFF status (logic level, 0, relays de-energized), and all instrument functions are inhibited except for the "Turn-on" function".

Turning on: press the "F" key for 5 seconds to switch the instrument from "OFF" to "ON" status. The instrument will run a setup cycle identical to a power-on, with flashing of all display segments for about 5 seconds, followed by normal functioning according to the HW and SW configuration. If the instrument is configured with self-tuning or soft start enabled, the appropriate procedure will be run as if following a power-on. If line voltage is cut during "OFF" status, at the next power-on the instrument will go to the same "OFF" status ("ON/OFF" status is saved). The function is normally enabled. The function is disabled by setting parameter Pro = Pro + 8 in phase CFG2.

• ALARM FUNCTIONS

Alarms can be absolute or deviation, direct or reverse, symmetrical deviation.

Absolute alarm: limit set with an absolute value compared to 0 (Ex. for 1000: set-point = 400, AL1 = 450, AL2 = 350, AL3 = 500).

Deviation alarm: limit set with an offset compared to setpoint (Ex. for 1000: set-point = 400, AL1 = +50, AL2 = -50, AL3 = +100).

Direct alarm: corresponding relay energized with controlled variable over set limit, in both absolute and deviation mode (maximum alarm).

For HB alarm, relay energized if current is below set value.

Reverse alarm: corresponding relay energized with controlled variable under set limit, in both absolute and deviation mode (minimum alarm).

For HB alarm, relay energized if current is above set value.

With symmetrical deviation alarm : the offset relative to the setpoint is both added and subtracted, defining an intervention window.

With absolute alarms, the limits take on at maximum the limits set in phase CFG2 (Lo.S and Hi.S).

With deviation alarms, the limits have values in range -199/+999 and the set value is added algebraically to the setpoint (the deviation alarm limit may extend below the lower limit or above the upper limit of the set scale) .

• CT (current transformer) INPUT

This input signals changes in load input, indicating the current value at the ammeter input in the set scale range.

The CT card (signaled by the brd code) lets you read the current in the CT secondary (5Aa.c) on the auxiliary analog input (terminals 6 and 7; see connection diagram). You can define the full scale current value directly referred to the load circuit with the Hb.S parameter in CFG.1 phase (example: for a CT 75/5A, set Hb.S = 75.0); by default, scale start is considered 0. Current reading is available in phase 5 in work mode (the lower display shows the whole value of current followed by letter "A," example: 45.A), or in the setting phase for the HB alarm limit on the upper display with resolution of a tenth of an Ampere (ex. 45.8).

Notes:

- The CT card lets you access the ammeter input calibration procedure (Hb.C).

- The CT input function can be used independently of the HB alarm to simply display the current at the ammeter input.

HB ALARM (Heater Break Alarm)

This type of alarm is conditioned on use of the current transformer (CT) input with setting of the brd code in phase CFG.2. The HB alarm function is independent of alarms AL1, AL2, AL3.

Enable by setting the Out code in phase CFG.2 to an odd value (bit1 = 1).

Enabling allows setting of the limit in work mode phase 4, with display of the ammeter input on the upper display and the limit with letter A flashing on the lower display (es. 25.A).

Press the Raise and Lower keys instead of letter A to show the decimal figure of the limit, which remains during the change.

When the keys are released, "A" reappears after one second.

With code A.r.F in phase CFG.2, you can assign the HB alarm to each of the alarm outputs installed (AL1, AL2, AL3). If it is not assigned to an output, the alarm state is still available in

read via serial line (if enabled) at address 10H (see Memory Map section).

The HB alarm function is selectable from 4 different modes by means of code Hb.F in phase CFG.2:

0 - alarm trips when load current drops below limit set for ON time of main output (evaluation time: 30 sec. including ON); turns off as soon as limit is exceeded.

1 - alarm trips when ammeter full scale (Hb.S) in OFF time is exceeded by 12%; turns off as soon as value drops below 12% limit.

2 - alarm trips if one of functions 0 and 1 (described above) is active (OR logic between functions 0 and 1)

3 - HB alarm for continuous output (PWM control, setting Ct = -1 or -2); with fixed duty cycle of 100msec.; does not take account of ON/OFF times and presupposes a special ammeter card with HW integration of load current.

The alarm trips if current drops below the set limit for 15 sec.

Functions only with power in output greater than 10% (2% for version 12); otherwise the alarm is deactivated. The alarm resets automatically if its cause is eliminated.

Deactivate the HB alarm by setting the limit to 0.

Notes:

- ON/OFF times refer to the set cycle time (see CT parameter in Programming phase 0).

LBA ALARM (Loop Break Alarm):

This alarm identifies interruption of the control loop due to a possible probe in short circuit, reversed probe, or load break.

If enabled (Lb.t <>0), it causes an alarm in case the variable value doesn't increase in heating (or doesn't decrease in cooling) under conditions of maximum power supplied for a set time (Lb.t) in range 0...240 min.

If the value of the variable is beyond the proportional band, power is limited to the set value (Lb.P) in range 0-100%.

The active alarm condition is signaled by flashing of the displays. By means of code A.r.F (in phase CFG.2) the LBA alarm can be assigned to each of the alarm outputs installed (AL1, AL2, AL3).

If it is not assigned to an output, the alarm state is still available in read via serial line (if enabled).

The alarm condition resets if the temperature increases in heating (decreases in cooling), or by means of the panel keys by simultaneously pressing the F and Raise keys for 3 seconds (press F first).

The LBA function is disabled by setting parameter Lb.t to 0.

11 • SELF-TUNING / AUTO-TUNING / SOFT-START / AUTO-MAN

TURNING ON SELF-TUNING

If enabled, this function starts when the instrument is turned on or by simultaneously pressing the F and Raise keys for 3 seconds.

The controlled variable flashes on the display. Self-tuning can be used only for heating systems. For very fast systems (100°C/min) limit PtU self-tuning power.

The function starts by supplying power (PtU). When temperature is reached (Setpoint-room temperature)/2, it turns power off and begins a wait phase to identify parameters.

The procedure ends with resumption of control, which uses the calculated parameters.

When the self-tuning phase ends (i.e., when peak is reached), the calculated parameters are saved and any preset parameters are lost.

To interrupt self-tuning when in progress, simultaneously press the F and Raise keys for 3 seconds (press F first).

The upper display stops flashing and the self-tuning function is deactivated and disabled (code S.tu in Phase 0 is automatically changed). Repeat this procedure to activate the self-tuning function (if enabled). With self-tuning enabled, the term "SOF" in CFG1 is replaced by PtU power value supplied in self-tuning phase in range 0...100%.

By setting Pt U = 0 Pt.U = 100% by default%.

TURNING ON AUTO-TUNING

If enabled, this function starts when the setpoint is reached for the first time (± 4 scale points).

The corrective action is on the value of the proportional band.

Auto-tuning is suspended each time the setpoint is changed, and the control parameters are returned to their starting values. Action resumes when the new setpoint is reached.

The proportional band cannot be changed during auto-tuning: you have to disable auto-tuning to do this.

TURNING ON THE SOFT-START FUNCTION

If enabled, this function partializes power as a percentage of the time elapsed since instrument turn-on compared to the time set (0...99.9 min) ("SOF" parameter, phase CFG1). Soft-start is an alternative to self-tuning, and is activated after each instrument turn-on.

AUTO/MAN FUNCTION, MANUAL CONTROL OF OUTPUT WITH BUMPLESS AT SWITCH TO AUTOMATIC

In normal operation, press the F key. After a scan of the alarm limits (and load current if applicable), the lower display shows the percentage of power supplied in output in the range 0...99% followed by letter P, while the upper display shows the process variable (PV).

99% is considered maximum power. This data remains on the display until the F key is pressed again, which returns the display to normal condition (PV/SP).

In MAN mode, you can set the control (power) output from the panel keys in the range 0.0...99.9%.

MAN mode is activated by simultaneously pressing the Raise and Lower keys in output display phase (indicated by letter P on the lower display).

You can set power in the above-mentioned range by means of the Raise and Lower keys.

In change phase, letter P is replaced by the decimal figure of the power level, which resumes flashing when the key is released.

99% is considered maximum power.

When switching to manual, the instrument delivers either the last manual power level saved or the automatic power at the time of switching, depending on the mode selected (Ctr code) configuration phase CFG.2. Press the F key to return to Automatic.

Switching from Manual to Automatic takes place in "BUMPLESS" mode if the process variable is within the proportional band.

The manual power value is saved. If the instrument is configured as ON-OFF controller:

In Automatic:

MAIN output = ON, corresponds to displayed power = 99;

MAIN output = OFF, corresponds to displayed power = 0;

In Manual:

Set power ≤ 49.9 corresponds to MAIN output = OFF;

Set power ≥ 50.0 corresponds to MAIN output = ON;

You can disable the MAN/AUTO function by setting the software protection to "Pro" = "Pro" + 16.

• ACCESSORIES

• RS 232 / TTL cable for configuration of GEFRA instruments



N.B.: RS232 interface for PC configuration è fornito is supplied with WINSTRUM programming software. make the connection with the device powered and with inputs and outputs disconnected.

• ORDER CODE

COD. 1108200

Cable + Floppy

ORDER CODE

MODEL	
1000	1000
1001	1001
1101	1101

MAIN OUTPUT	
Relay / Logic	R0
0...10V	V
0/4...20mA	I

ALARMS	
1 Alarm	1R (°)
2 Alarms	2R
3 Alarms	3R
HB	1H (°)
1 Alarm + HB	2H
2 Alarms + HB	3H

DIGITAL COMMUNICATIONS	
None	0
Current Loop	1
RS485	2

STANDARD CONFIGURATION HW and SW	
- With HW/SW configuration protection	
Setpoint = 400	_no = 1
AL1 = 100	bAU = 0
AL2 = -100	FA.P = 0
AL3 = 600	Pro = 19
Pb = 1,0%	AL = 11
rSt = 0	Out = 0
Ct = 20sec	Typ = 0
PSt = 0%	Ct.a = 20sec
S.tu = 0	dt.A = 1,00min
Lb.t = 0min	oFt = 0
Lb.P = 25%	LO.S = 0
It = 4,0min	HI.S = 800
dt = 1,0min	rEL = 0
SOF = 0	Ar.F = 0
Hy1 = 1	Ctr = 0
Hy2 = 1	Hbf = 0
Hy3 = 1	brd = 4 (1000)
Hb.S = 25,0	6 (1001)

POWER SUPPLY	
0	11...27Vac/dc
1	100...240Vac/dc

(°) Only type if the serial interface is requested

Please, contact GEFTRAN sales people for the codes availability.

• WARNINGS



WARNING: this symbol indicates danger.

It is placed near the power supply circuit and near high-voltage relay contacts

Read the following warnings before installing, connecting or using the device:

- follow instructions precisely when connecting the device
- always use cables that are suitable for the voltage and current levels indicated in the technical specifications
- the device has NO on/off switch: it switches on immediately when power is turned on. For safety reasons, devices permanently connected to the power supply require a two-phase disconnecting switch with proper marking. Such switch must be located near the device and must be easily reachable by the user. A single switch can control several units
- if the device is connected to electrically NON-isolated equipment (e.g. thermocouples), a grounding wire must be applied to assure that this connection is not made directly through the machine structure
- if the device is used in applications where there is risk of injury to persons and/or damage to machines or materials, it must be used with auxiliary alarm units. You should be able to check the correct operation of such units during normal operation of the device
- before using the device, the user must check that all device parameters are correctly set in order to avoid injury to persons and/or damage to property
- the device must NOT be used in inflammable or explosive environments. It may be connected to units operating in such environments only by means of suitable interfaces in conformity to local safety regulations
- the device contains components that are sensitive to static electrical discharges. Therefore, take appropriate precautions when handling electronic circuit boards in order to prevent permanent damage to these components

Installation: installation category II, pollution level 2, double isolation;

only for power supply 11/27Vac/dc: supply from Class2 or low voltage limited energy source

- power supply lines must be separated from device input and output lines; always check that the supply voltage matches the voltage indicated on the device label
- install the instrumentation separately from the relays and power switching devices
- do not install high-power remote switches, contactors, relays, thyristor power units (particularly if "phase angle" type), motors, etc... in the same cabinet.
- avoid dust, humidity, corrosive gases and heat sources
- do not close the ventilation holes; working temperature must be in the range of 0...50°C
- surrounding air: 50°C

If the device has faston terminals, they must be protected and isolated; if the device has screw terminals, wires should be attached at least in pairs.

- use 60/75°C copper (Cu) conductor only wire size range 2xNo 22-14AWG, Solid / Stranded
- terminal tightening torque 0,5Nm
- **Power:** supplied from a disconnecting switch with fuse for the device section; path of wires from switch to devices should be as straight as possible; the same supply should not be used to power relays, contactors, solenoid valves, etc.; if the voltage waveform is strongly distorted by thyristor switching units or by electric motors, it is recommended that an isolation transformer be used only for the devices, connecting the screen to ground; it is important for the electrical system to have a good ground connection; voltage between neutral and ground must not exceed 1V and resistance must be less than 60hm; if the supply voltage is highly variable, use a voltage stabilizer for the device; use line filters in the vicinity of high frequency generators or arc welders; power supply lines must be separated from device input and output lines; always check that the supply voltage matches the voltage indicated on the device label
- **Input and output connections:** external connected circuits must have double insulation; to connect analog inputs (TC, RTD) you have to: physically separate input wiring from power supply wiring, from output wiring, and from power connections; use twisted and screened cables, with screen connected to ground at only one point; to connect adjustment and alarm outputs (contactors, solenoid valves, motors, fans, etc.), install RC groups (resistor and capacitor in series) in parallel with inductive loads that work in AC (*Note: all capacitors must conform to VDE standards (class x2) and support at least 220 VAC. Resistors must be at least 2W*); fit a 1N4007 diode in parallel with the coil of inductive loads that operate in DC

GEFRAN spa will not be held liable for any injury to persons and/or damage to property deriving from tampering, from any incorrect or erroneous use, or from any use not conforming to the device specifications.

CONFIGURAZIONE HARDWARE HARDWARE CONFIGURATION HARDWARE-KONFIGURATION

CONFIGURATION MATÉRIELLE HARDWARE CONFIGURACIÓN HARDWARE CONFIGURAÇÃO DO HARDWARE

Per estrarre la parte elettronica dalla custodia agire sulla vite frontale fino allo sblocco, quindi estrarre manualmente.
La configurazione si effettua sulle schede: ingresso_CPU, alimentazione_uscite e opzionali.

To remove the electronic part of the case, loosen the front screw until release, then remove by hand.
Configuration is performed on the input board, the output/power board, and on the optional board.

Um den kompletten Elektronikeinschub mit der Hand aus dem Gehäuse herausziehen zu können, muss man die Befestigungsschraube auf der Frontplatte lösen. Die Konfiguration erfolgt auf der Eingangskarte, der Ausgangs-/Netzteilkarte und der optionalen Karte.

Pour extraire la partie électronique du boîtier, agir sur la vis frontale jusqu'au déblocage, puis retirer à la main.
La configuration s'effectue sur la carte d'entrée, de sortie/alimentation et sur la petite carte en option.

Para extraer la parte electrónica de la carcasa operar con el tornillo frontal hasta obtener el desbloqueo y a continuación extraer manualmente.
La configuración se efectúa en la ficha de entrada, de salida/alimentación y en la ficha opcional.

Para extrair a parte eletrônica da custódia, opere no parafuso frontal até à liberação e depois tire à mão.
A configuração leva-se a efeito na placa de entrada, de saída/alimentação e na placa opcional.

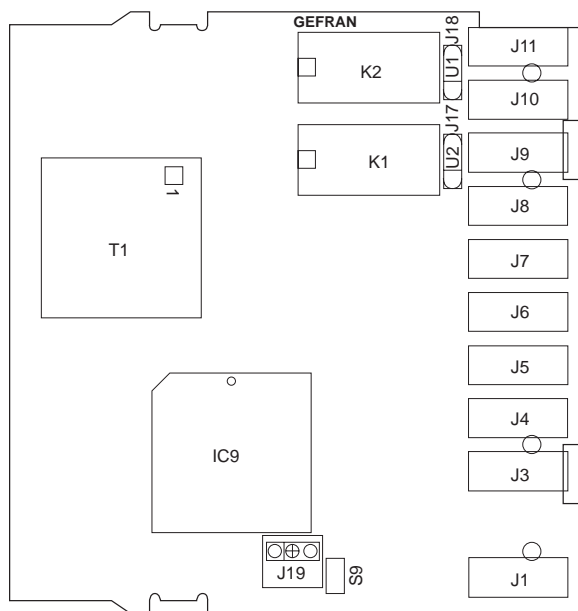

45189x_ic
45196x_ic

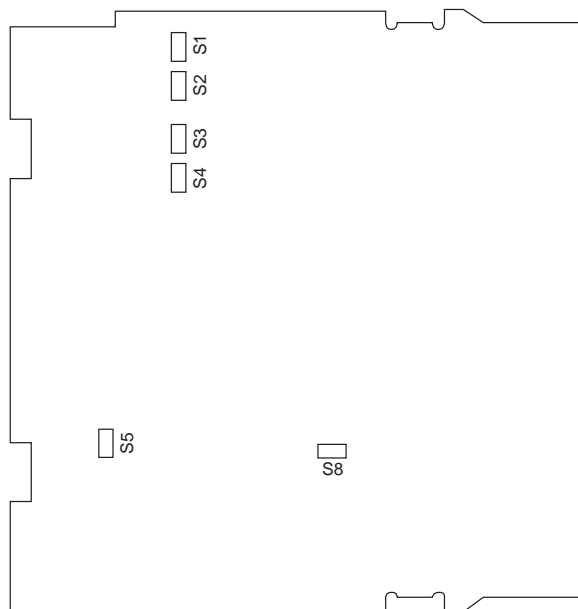

45189x_is
45196x_is

Scheda ingresso_CPU

Sulla scheda sono posizionati i ponticelli per l'abilitazione/disabilitazione della configurazione e calibrazione come descritto nella seguente tabella:

Descrizione	Posizione ponticello jumper 45189x_Ic / 45196x_Ic (lato componenti)	Ponticelli a stagno 45189x_Is / 45196x_Is (lato saldature)
Configurazione abilitata	S9 chiuso	
Configurazione disabilitata	S9 aperto	
Calibrazione abilitata		S8 chiuso
Calibrazione disabilitata		S8 aperto

Lo strumento é fornito con configurazione abilitata e calibrazione disabilitata.

CPU_input board

The input board has jumpers to enable/disable configuration and calibration as described in the following table:

Description	Jumper position 45189x_Ic / 45196x_Ic (component side)	Soldered jumpers 45189x_Is / 45196x_Is (solder side)
Configuration enabled	S9 closed	
Configuration disabled	S9 open	
Calibration enabled		S8 closed
Calibration disabled		S8 open

The instrument is supplied with enabled configuration and disabled calibration.

Eingangskarte_CPU

Auf der Eingangskarte befinden sich nach den Angaben in der nachstehenden Tabelle die Brücken für die Freigabe bzw. Sperrung der Konfiguration und der Kalibration:

Bezeichnung	Position der Brücke 45189x_Ic / 45196x_Ic (Bestückungsseite)	Lötbrücken 45189x_Is / 45196x_Is (Lötseite)
Konfiguration freigegeben	S9 geschlossen	
Konfiguration gesperrt	S9 offen	
Kalibration freigegeben		S8 geschlossen
Kalibration gesperrt		S8 offen

Bei Lieferung des Geräts sind Konfiguration freigegeben und Kalibration gesperrt.

Carte Entrées_CPU

Sur la carte entrées se trouvent les cavaliers pour la validation/inhibition de la configuration et la calibration, comme indiqué dans le tableau suivant:

Description	Positionnement cavalier 45189x_Ic / 45196x_Ic (côté composants)	Ponticelli a stagno 45189x_Is / 45196x_Is (côté soldures)
Configuration validée	S9 fermé	
Configuration inhibée	S9 ouvert	
Calibration validée		S8 fermé
Calibration inhibée		S8 ouvert

L'appareil est fourni avec configuration validée et calibration inhibée.

Ficha entradas_CPU

En la ficha entradas están posicionados los puentes para la habilitación/inhabilitación de la configuración y calibración tal como se indica en la siguiente tabla:

Descripción	Posicionamiento puente 45189x_Ic / 45196x_Ic (lado componentes)	Puente de estaño 45189x_Is / 45196x_Is (lado soldadura)
Configuración habilitada	S9 cerrado	
Configuración inhabilitada	S9 abierto	
Calibración habilitada		S8 cerrado
Calibración inhabilitada		S8 abierto

El instrumento se suministra con configuración habilitada y calibración inhabilitada.

Placa de Entradas_CPU

As pontes para habilitação/desabilitação da configuração e calibração estão posicionadas na placa de entradas conforme descrito na tabela seguinte:

Descrição	Posicionamento da ponte 45189x_Ic / 45196x_Ic (lado componentes)	Pontes com estanho 45189x_Is / 45196x_Is (lado soldaduras)
Configuração habilitada	S9 fechada	
Configuração desabilitada	S9 aberta	
Calibração habilitada		S8 fechada
Calibração desabilitada		S8 aberta

O instrumento é fornecido com configuração habilitada e calibração desabilitada.

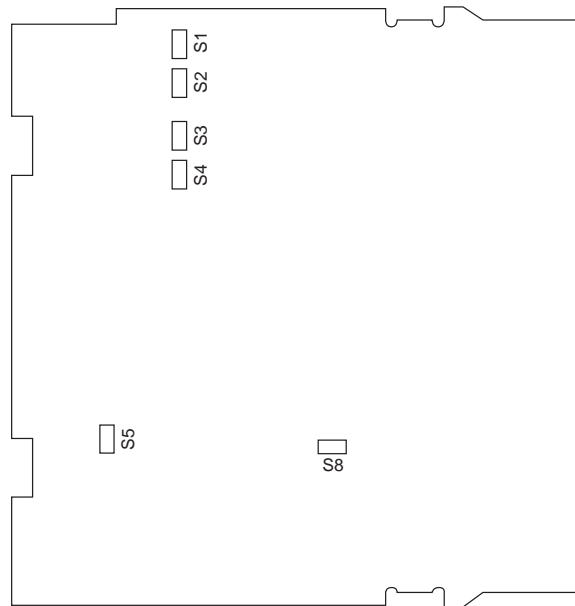

45189x_Is
45196x_Is

Opzione allarmi 2 e 3

Selezione contatti NO/NC per relè di allarme 2 e 3. Normalmente gli allarmi 2 e 3 vengono forniti con contatti NO, per ottenere la versione NC è necessario rimuovere manualmente i rispettivi ponticelli NO ed effettuare quelli NC.

Allarme 2 NC	S1 (45189x_Is / 45196x_Is)
Allarme 2 NO	S2 (45189x_Is / 45196x_Is)
Allarme 3 NC	S3 (45189x_Is / 45196x_Is)
Allarme 3 NO	S4 (45189x_Is / 45196x_Is)

Optional alarms 2 and 3

Select N.O./N.C. alarm relay contacts 2/3. Normally, alarms 2 and 3 are supplied N.O.; for the N.C. version, you have to manually remove the N.O. jumpers and install the N.C. jumpers.

Alarm 2 NC	S1 (45189x_Is / 45196x_Is)
Alarm 2 NO	S2 (45189x_Is / 45196x_Is)
Alarm 3 NC	S3 (45189x_Is / 45196x_Is)
Alarm 3 NO	S4 (45189x_Is / 45196x_Is)

Optionale Alarme 2 und 3

Wahl von Schließer/Öffner für Alarmrelais 2 und 3. Normalerweise sind die Alarme 2 und 3 als Schließer konfiguriert; zur Wahl des Öffnerkontakts muss die Brücke NO entfernt und die Brücke NC eingesetzt werden.

Alarme 2 NC	S1 (45189x_Is / 45196x_Is)
Alarme 2 NO	S2 (45189x_Is / 45196x_Is)
Alarme 3 NC	S3 (45189x_Is / 45196x_Is)
Alarme 3 NO	S4 (45189x_Is / 45196x_Is)

Option alarmes 2 et 3

Sélection contacts NO/NF relais 2/3 d'alarme. Normalement les alarmes 2 et 3 sont fournies NO; pour avoir la version NF, il est nécessaire de retirer manuellement les cavaliers NO respectifs et de réaliser les cavaliers NF.

Alarme 2 NF	S1 (45189x_Is / 45196x_Is)
Alarme 2 NO	S2 (45189x_Is / 45196x_Is)
Alarme 3 NF	S3 (45189x_Is / 45196x_Is)
Alarme 3 NO	S4 (45189x_Is / 45196x_Is)

Opcional alarmas 2 y 3

Selección contactos N.A./N.C. relé 2/3 de alarma. Normalmente las alarmas 2 y 3 se suministran N.A.; para obtener la versión N.C. es necesario retirar manualmente los respectivos puentes N.A. y aplicar aquéllos N.C.

Alarma 2 N.C.	S1 (45189x_Is / 45196x_Is)
Alarma 2 N.A.	S2 (45189x_Is / 45196x_Is)
Alarma 3 N.C.	S3 (45189x_Is / 45196x_Is)
Alarma 3 N.A.	S4 (45189x_Is / 45196x_Is)

Opcional alarmes 2 e 3

Seleção de contatos N.A./N.F. para relés de alarme 2/3. Normalmente, os alarmes 2 e 3 são fornecidos N.A.; para ter a versão N.F. é necessário remover manualmente as pontes respectivas N.A. e fazer as N.F.

Alarme 2 N.F.	S1 (45189x_Is / 45196x_Is)
Alarme 2 N.A.	S2 (45189x_Is / 45196x_Is)
Alarme 3 N.F.	S3 (45189x_Is / 45196x_Is)
Alarme 3 N.A.	S4 (45189x_Is / 45196x_Is)

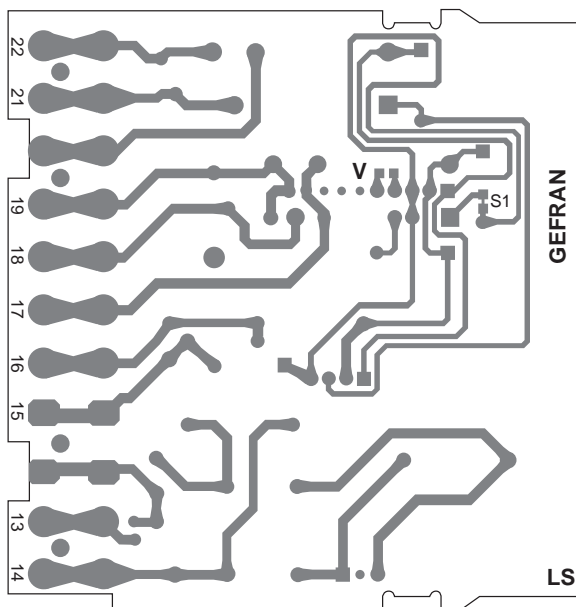

451901_Is

Scheda alimentazione_uscite

- Uscita principale D2
Quando si utilizza l'uscita D2 é consigliabile escludere l'attività del relé di MAIN togliendo manualmente il ponticello S1.
- Uscita principale in continua V/I
Per ottenere l'uscita in tensione effettuare il ponticello V, con il ponticello aperto l'uscita é in corrente.

Output/power board

- Main output D2
When output D2 is used, we advise you to exclude the MAIN relay by manually removing jumper S1.
- Main output in direct current and voltage
Insert jumper V for output in voltage. Without the jumper, the output is in current.

Ausgangs-/Netzteilkarte

- Regelausgang D2
Bei Verwendung des Ausgangs D2 empfiehlt es sich, die Brücke S1 von Hand zu entfernen, um das Relais MAIN abzuschalten.
- Regelausgang in Gleichspannung und -strom
Für den Spannungsausgang die Brücke V schließen; bei geöffneter Brücke ist der Ausgang in Strom.

Carte sortie/alimentation

- Sortie principal D2
Quand on utilise la sortie D2, il est conseillé de désactiver l'activité du relais MAIN en retirant manuellement le cavalier S1.
- Sortie principale en tension et courant continu
Pour obtenir la sortie de tension, réaliser le cavalier V ; le cavalier ouvert, la sortie est sous courant

Ficha salida/alimentación

- Salida principal D2
Para utilizar la salida D2 se aconseja desactivar el relé de MAIN retirando manualmente el puente S1.
- Salida principal en tensión y corriente continua
Para obtener la salida en tensión colocar el puente V; con el puente abierto la salida está en corriente.

Placa de saída/alimentação

- Saída principal D2
Quando se utiliza a saída D2, é aconselhável excluir a atividade do relé da saída principal, eliminando, manualmente, a ponte S1.
- Saída principal em tensão e corrente contínua
Para obter a saída em tensão construa a ponte V, com a ponte aberta a saída é em corrente.

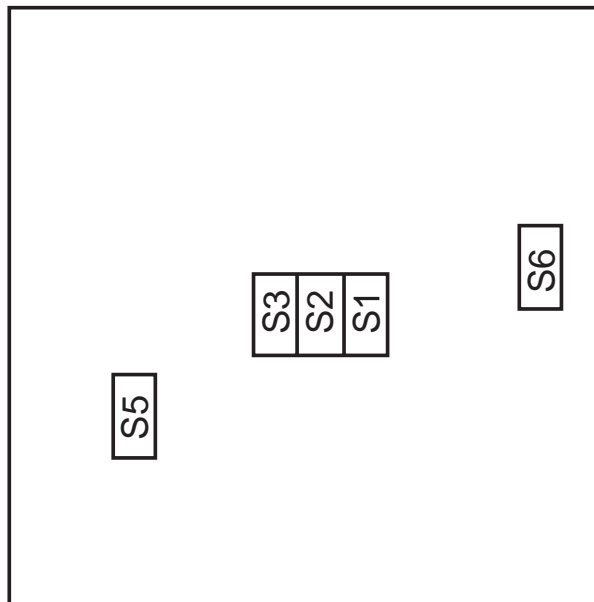

45195x_Is

Scheda seriale current loop (cod 1 in sigla di ordinazione)

Per collegamento parallelo (standard) chiudere S5 (S6 off).
 Per collegamento serie chiudere S6 (S5 off).
 S5 e S6 si trovano sul lato saldature della scheda 45195x_Is.

Current loop serial board (code 1 in order code)

Close S5 (S6 off) for parallel (standard connection).
 Close S6 (S5 off) for serial connection.
 S5 and S6 are on the component side of the 45195_lc board.

Seriell-Current-Loop-Karte (Kode 1 in der Bestellnummer)

Für den parallelen Anschluss (Standard) S5 schließen (S6 off).
 Für den seriellen Anschluss S6 schließen (S5 off).
 S5 und S6 befinden sich auf der Bestückungsseite der Karte 45195x_Is.

Carte série boucle de courant (code 1 dans le sigle de commande)

Pour le branchement parallèle (standard), fermer S5 (S6 off).
 Pour le branchement série, fermer S6 (S5 off).
 S5 et S6 sont situés sur le côté composants de la carte 45195x_Is.

Ficha serie current loop (cód. 1 en sigla de pedido)

Para conexión paralela (estándar) cerrar S5 (S6 off).
 Para conexión serie cerrar S6 (S5 off).
 S5 y S6 se encuentran en el lado componentes de la tarjeta 45195x_Is.

Placa serial current loop (1 no código de pedido)

Para ligação em paralelo (padrão) feche S5 (S6 off).
 Para ligação em série, feche S6 (S5 off).
 S5 e S6 estão no lado de componentes da placa 45195x_Is.

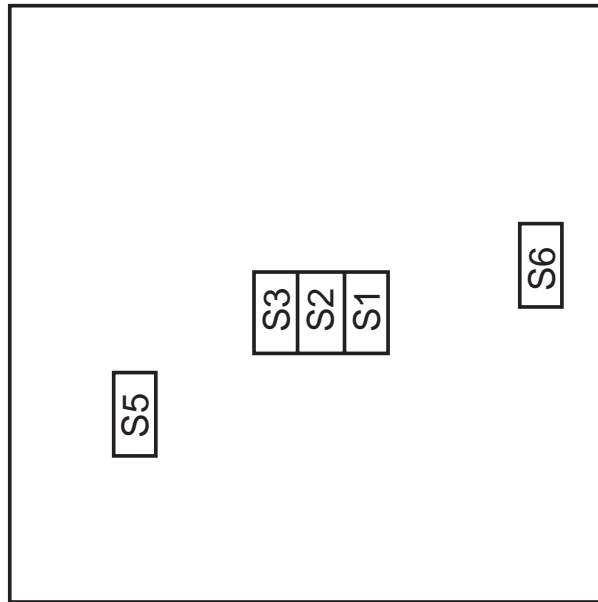

45195x_Is

Scheda seriale RS485 (cod 2 in sigla di ordinazione)

La linea seriale RS485 può essere polarizzata eseguendo i ponticelli di stagno S1, S2 e S3 presenti sul lato saldature della scheda 45195x_Is. La distanza di trasmissione coperta dall'uscita seriale RS485 degli strumenti raggiunge i 500 metri con un massimo di 32 strumenti collegati. Per ulteriori informazioni consultare il manuale delle comunicazioni seriali codice 80034.

RS485 serial output (code 2 in order code)

The RS485 serial line can be polarized by installing soldered jumpers S1, S2 and S3 on the solder side of the board 45195x_Is. The transmission distance of serial output RS485 aches 500 meters with a maximum of 32 instruments connected. For more information, see serial communication manual code 80034.

Serieller Ausgang RS485 (Code 2 im Bestellcode)

Die serielle Schnittstelle RS485 kann durch die Lötbrücken S1, S2 und S3 auf der Lötseite der Karte polarisiert werden 45195x_Is. Die Übertragungsdistanz des seriellen Ausgangs RS485 des Geräts beträgt bei einer maximalen Anzahl von 32 angeschlossenen Geräten bis zu 500 m. Für weitere Informationen siehe das Handbuch für die serielle Übertragung Kode 80034.

Sortie série RS485 (code 2 dans la référence de commande)

La ligne série RS485 peut être polarisée en réalisant les cavaliers en étain S1, S2 et S3 présents sur le côté soudures de la carte 45195x_Is. La distance de transmission couverte par la sortie série RS485 des appareils atteint 500 mètres avec un maximum de 32 appareils raccordés. Pour plus d'informations, se reporter au manuel des communications série, code 80034.

Salida serial RS485 (cód. 2 en sigla de pedido)

La línea serie RS485 puede polarizarse aplicando los puentes de estaño S1, S2 y S3 presentes en el lado soldaduras de la ficha 45195x_Is. La distancia de transmisión cubierta por la salida serial RS485 de los instrumentos alcanza los 500 metros con un máximo de 32 instrumentos conectados. Para mayores informaciones consúltese el manual de las comunicaciones serie código 80034.

Saída serial RS485 (cód. 2 no código de pedido)

A linha serial RS485 pode ser polarizada, fazendo as pontes de estanho S1, S2 e S3, presentes no lado de soldaduras da placa 45195x_Is. A distância de transmissão coberta pela saída serial RS485 dos instrumentos chega até 500 metros, com um máximo de 32 instrumentos ligados na mesma linha. Para mais informações consulte o manual das comunicações seriais, código 80034.

GEFRAN



ISO 9001

GEFRAN spa
via Sebina, 74 - 25050 Provaglio d'Iseo (BS) - ITALIA
Tel. +39 0309888.1 - Fax +39 0309839063
www.gefran.com
www.gefranonline.com